



US 20120060267A1

(19) **United States**
(12) **Patent Application Publication**
BLENKARN et al.

(10) **Pub. No.: US 2012/0060267 A1**
(43) **Pub. Date: Mar. 15, 2012**

(54) **AIRBAG RESCUE SYSTEM**

Publication Classification

(75) Inventors: **Michael Douglas BLENKARN**,
North Vancouver (CA); **Thomas
Walker Clarke FAYLE**, North
Vancouver (CA); **Gordon
Thompson ROSE**, Bowen Island
(CA)

(51) **Int. Cl.**
A62B 17/00 (2006.01)

(52) **U.S. Cl.** 2/456

(73) Assignee: **ARC'TERYX EQUIPMENT
INC.**, North Vancouver (CA)

(57) **ABSTRACT**

(21) Appl. No.: **13/231,330**

(22) Filed: **Sep. 13, 2011**

The invention is directed to an airbag system and, more particularly, to such a system employed as a rescue or life-saving system to enable a person to survive an avalanche. In a particular embodiment, the invention relates to an airbag system utilized with a backpack to be worn by a skier, snowboarder, hiker, or snowmobiler, for example. Instead of relying upon compressed gas cartridges or cylinders to inflate the airbag(s), the invention inflates the airbag(s) with ambient air only. In a particular embodiment, air is supplied to the airbag by means of a battery-powered electrical motor.

Related U.S. Application Data

(60) Provisional application No. 61/382,732, filed on Sep. 14, 2010.

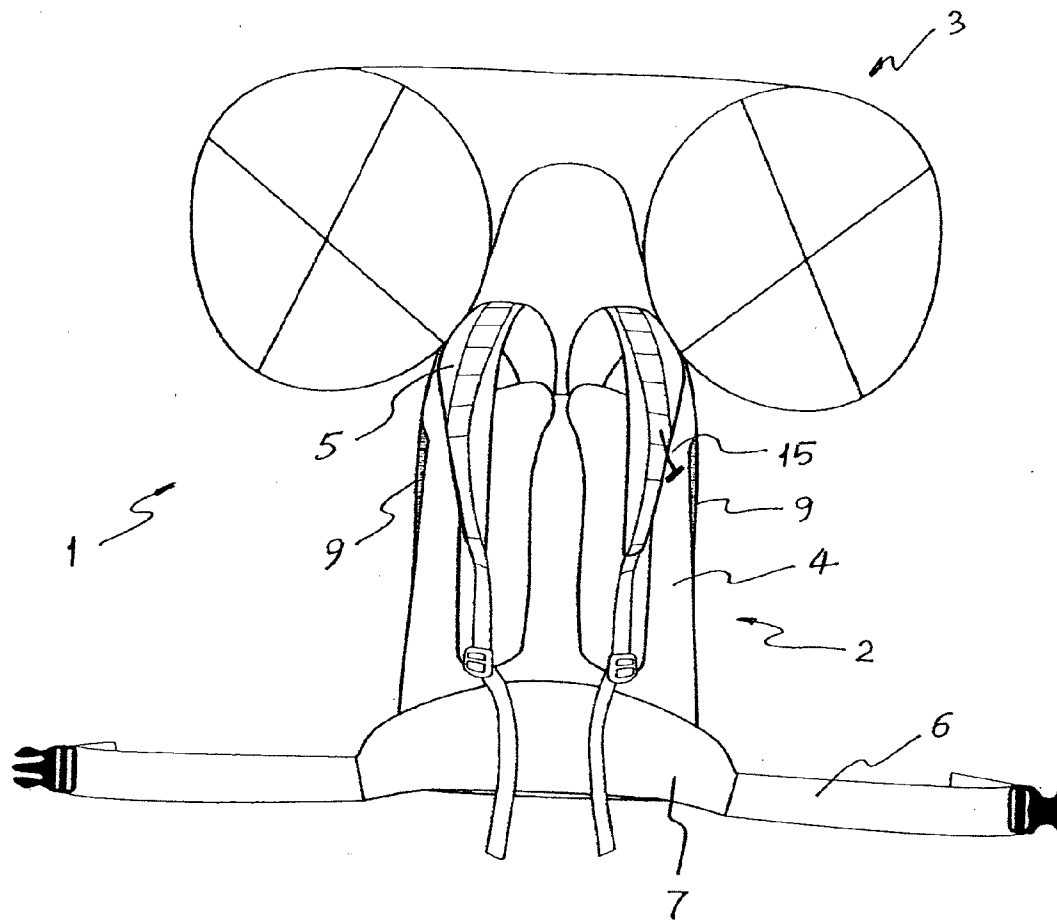

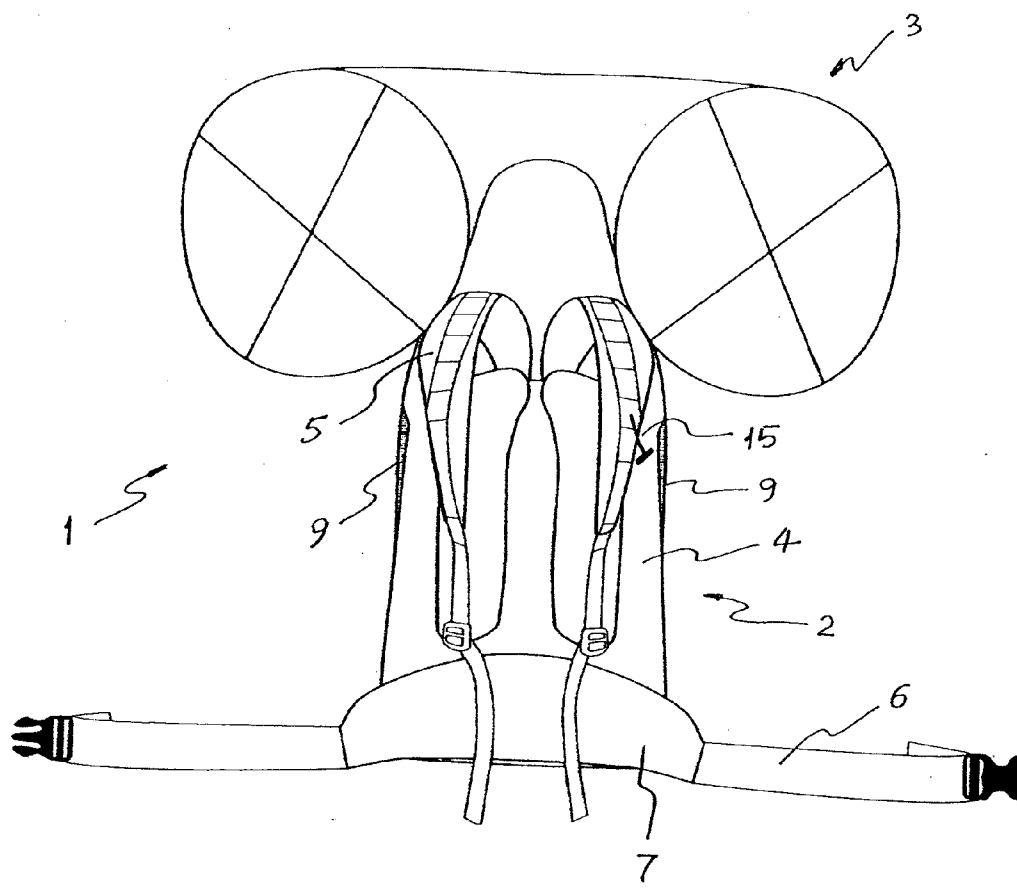

FIG. 1

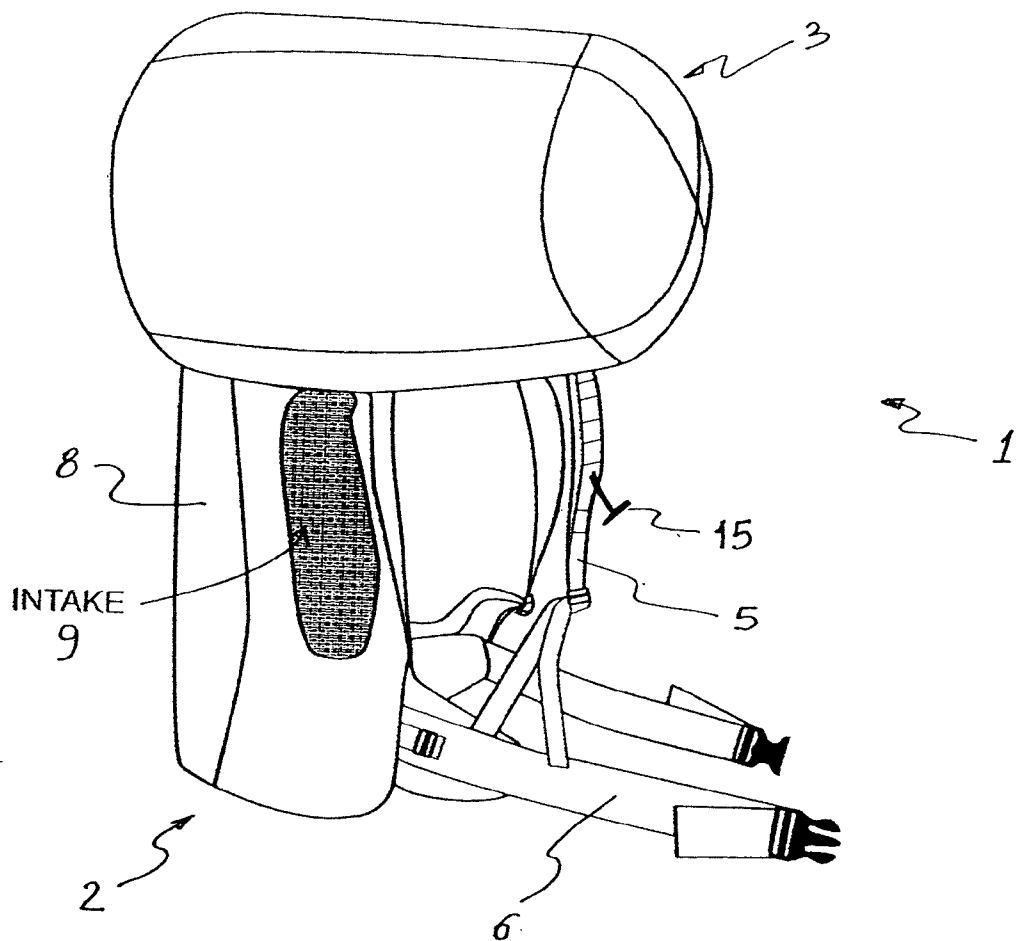

FIG. 2

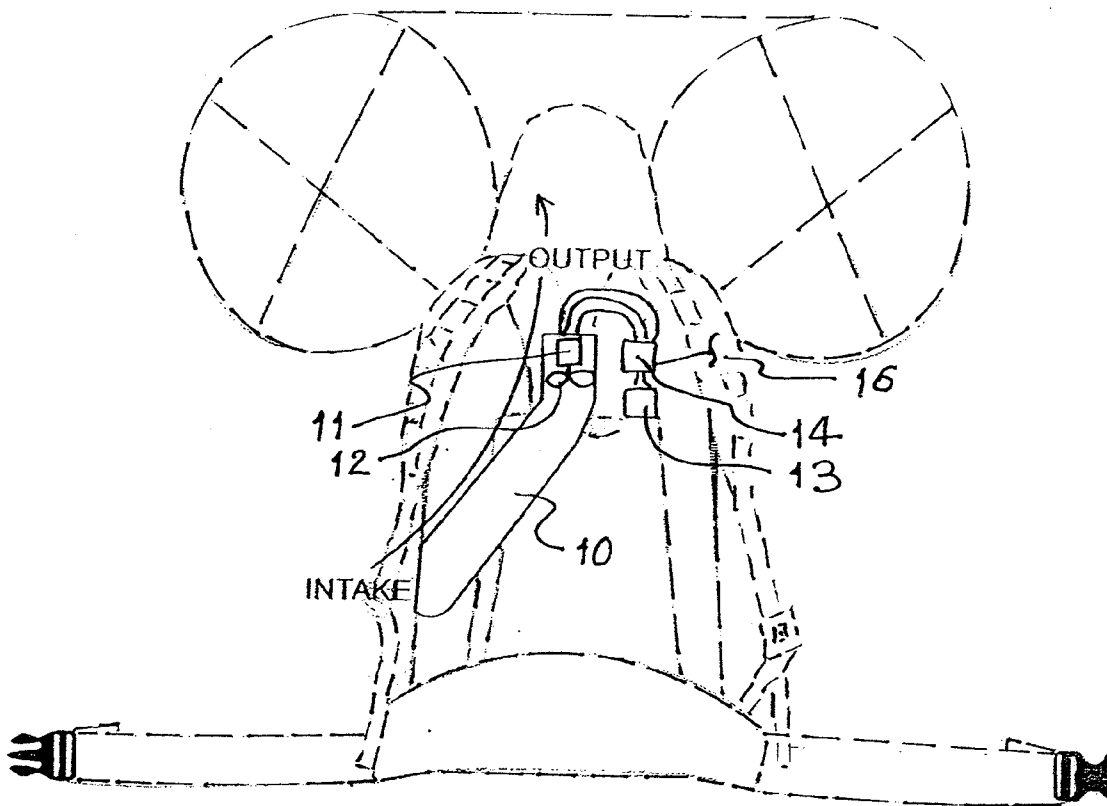

FIG. 3

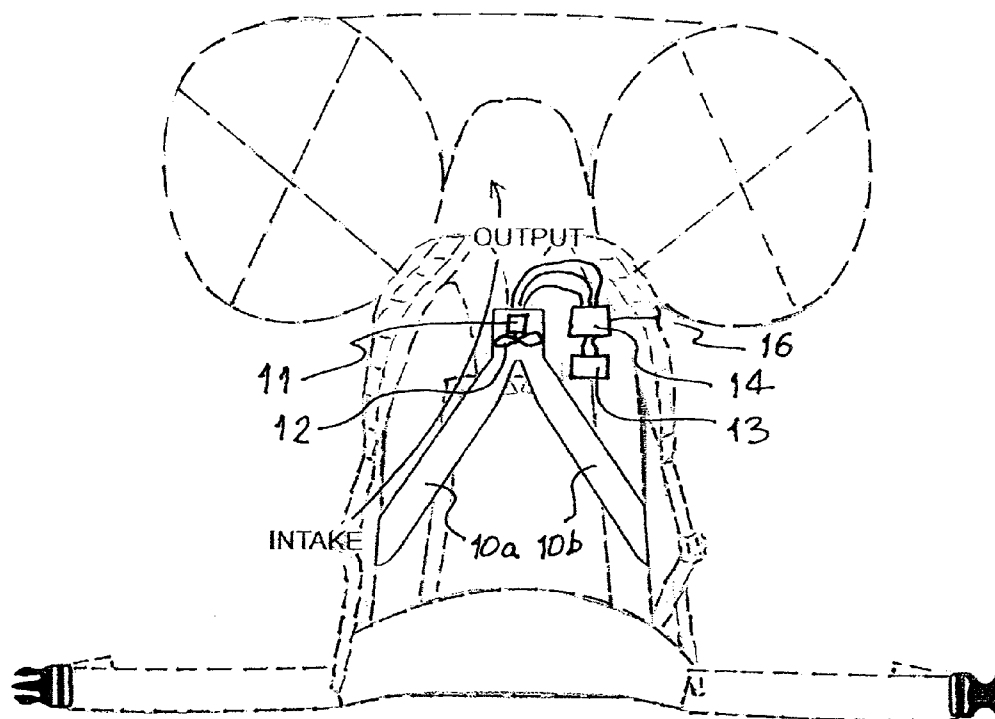

FIG. 4

Assembly schematic of centrifugal avalanche air-bag blower, showing power supply, digital control, ducting, and mounting to airbag

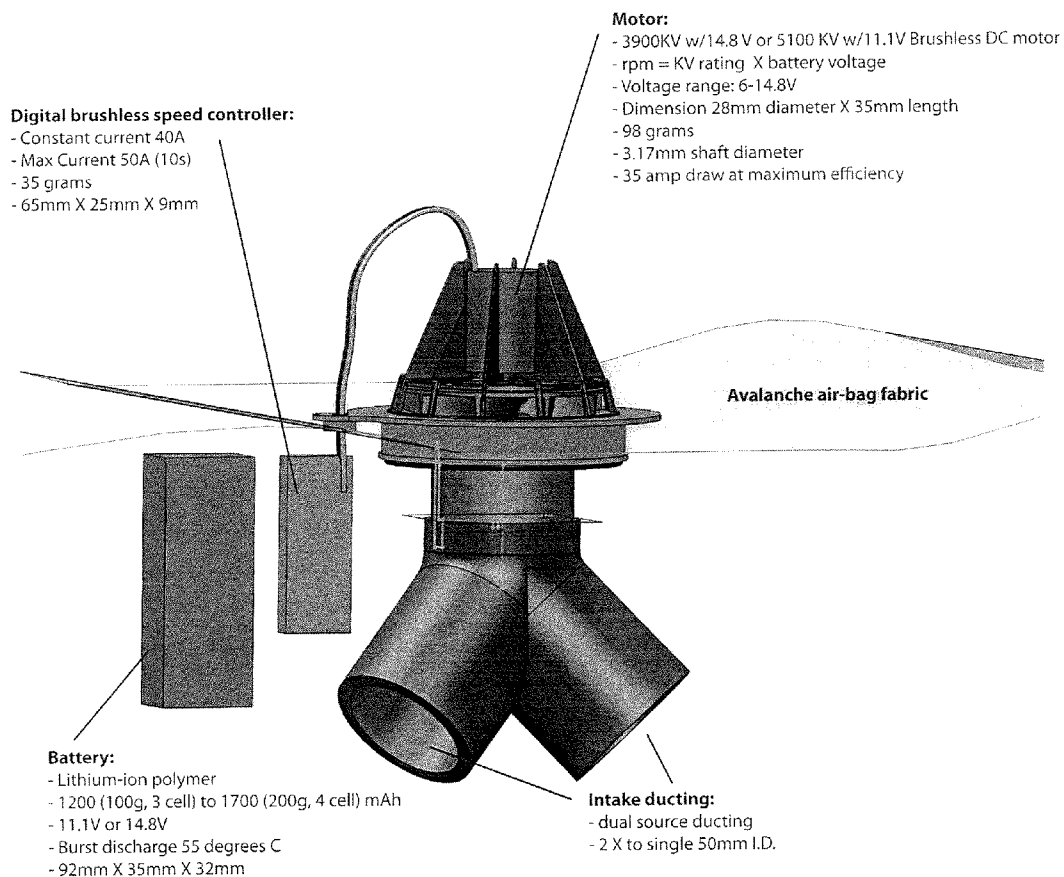

FIG. 5

Exploded view of centrifugal blower and motor for avalanche air-bag

FIG. 6

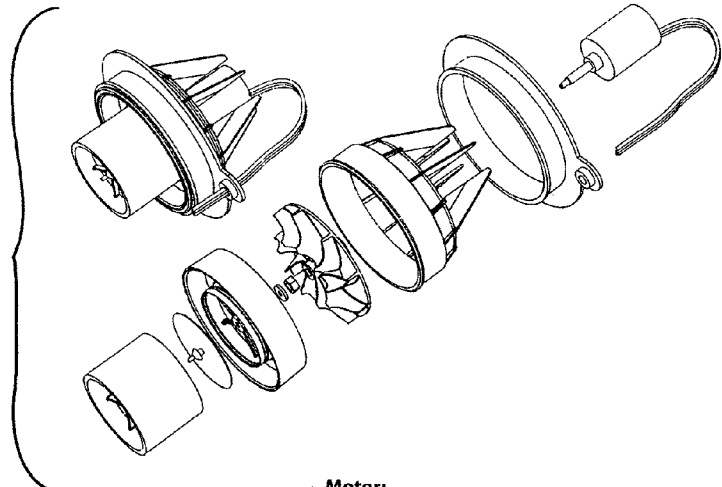
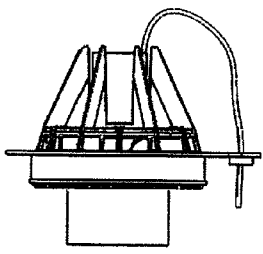

FIG. 7



- Motor:**
 - 3900KV Brushless DC motor (3900 rpm/volt)
 - Voltage range: 6-14.8V
 - Dimension 28mm diameter X 35mm length
 - 98 grams
 - 3.17mm shaft diameter
 - 35 amp draw at maximum efficiency

- Mounting flange:**
 - Thermoplastic Polyurethane
 - wiring port
 - sews or welds to air-bag
 - blower assembly installed with circular clamp

- Motor mount / rotor casing:**
 - nylon 6,6
 - heat guard for air-bag fabric
 - rotor blade guardds

- Washer:**
 - low friction (PTFE)

- Rotor:**
 - fibre reinforced nylon 6,6
 - helical blade centrifugal rotor (7 or 9 blade)

- Nut:**
- Washer:**
 - low friction (PTFE)

- Ball bearing:**
 - 3.17mm inside diameter

- Rotor casing / Intake duct:**
 - nylon 6,6
 - 50mm i.d. duct intake
 - ball bearing bracket

- Diaphragm check valve:**
 - silicone

- Check valve housing:**
 - nylon 6,6

AIRBAG RESCUE SYSTEM

CROSS-REFERENCE TO RELATED APPLICATION

[0001] This application is based upon U.S. Provisional Patent Application No. 61/382,732, filed Sep. 14, 2010, the disclosure of which is hereby incorporated by reference thereto in its entirety, and the priority of which is claimed under 35 U.S.C. §119(e).

BACKGROUND OF THE INVENTION

[0002] 1. Field of the Invention

[0003] The invention relates to an airbag system and, more particularly, to an airbag rescue or safety system and, even more particularly, an airbag system employed as a life-saving system to enable a person using such system to survive an avalanche, or analogous situation, such as a water rescue, e.g., as well as an airbag system for attachment to, and for recovering, equipment of the person, such as a snowmobile.

[0004] More particularly, such a system can be used when activated (either remotely or manually by the user) to maintain the user or the user's equipment buoyant during an avalanche, or analogous situation, and to maintain the user or equipment on the surface of the avalanche, or as close to the surface as possible, thereby enabling the user to survive the avalanche or to facilitate recovery of the user's equipment.

[0005] In a further particular implementation, the field of invention relates to an airbag system utilized with a harness or backpack to be worn by a skier, snowboarder, snowmobiler, hiker, or a person engaged in another activity, who risks being exposed to an avalanche or analogous situation. In this regard, the invention also relates to a system attachable to an item of gear, such as a snowmobile or other sports gear, for example, which system can be remotely activated.

[0006] 2. Background Information

[0007] Currently, so-called avalanche airbags, embodied as backpack systems to be worn by a skier, include those marketed by ABS Peter Aschauer GmbH, Snowpulse S.A., and Backcountry Access, Inc. Such systems are disclosed in the following documents: U.S. Pat. No. 4,635,754; U.S. Pat. No. 6,158,380; U.S. Pat. No. 6,220,909; U.S. Patent Application Publication No. 2009/0239428; U.S. Patent Application Publication No. 2010/0112880; and U.S. Patent Application Publication No. 2010/0184343.

[0008] These systems are designed to prevent burial in an avalanche and to enable the victim to survive an avalanche with the fewest possible injuries when wearing a backpack which incorporates such a system. These systems are intended to have the wearer stay on the surface of the avalanche or as close to the surface as possible.

[0009] In this regard, after activation and inflation, the inflated airbag secured to the victim increases the combined volume compared to the volume of the victim without such a system, thereby having the effect of keeping the victim at or near the surface of the flow of the snow during an avalanche. Further, sufficiently reducing the combined weight/volume ratio of the victim wearing an inflated airbag, i.e., to less than that of the snow, maintains the victim relatively buoyant and at the surface of the snow.

[0010] When activated, the ABS avalanche airbag deploys a pair of vertically elongated airbags on the sides of the back of the wearer, whereas the Snowpulse system deploys an airbag that surrounds the wearer's head. ABS claims that the

unobstructed vision and freedom of movement, even with the inflated airbags, allow the wearer to escape an avalanche and make it possible to react when caught in an avalanche and to assume a protective position. The single-bag system of Snowpulse is designed to provide protection to the head and thorax of the wearer which, in addition to providing protection against burial, also protects against traumas. In either case, the system is intended to maintain the wearer at or near the surface of the avalanche and is not dependent solely on a rescue or avalanche beacon. ABS claims that 98% of all avalanche victims who activated their ABS avalanche airbag have survived, while 90% of this group were completely uninjured.

[0011] The aforementioned U.S. Patent Application Publication No. US 2010/0184343 of Backcountry Access, Inc. describes in detail the current related art of avalanche airbag backpacks and gives a history and general description of the construction, use, and intent of this category of equipment.

[0012] Each of the systems known in this field of technology, including the aforementioned systems of ABS, Snowpulse, and Backcountry Access, Inc., relies upon a one-time use container of compressed gas (such as air or nitrogen) to inflate the airbag(s). Some of these one-time use systems also incorporate a means of drawing in ambient air to increase the total volume of gas by means of a venturi or an ejector, but such means nevertheless require the compressed gas for drawing in the ambient air.

[0013] Despite the success and advantages offered by avalanche airbags known in the art, many problems are inherent with the use of compressed gas containers, i.e., cylinders and cartridges. For example, compressed gas systems are limited by their one-time use. Once the compressed gas is expelled, a new cylinder or cartridge must be installed or the empty one refilled prior to re-use.

[0014] In addition, due to size and weight constraints of compressed gas cylinders/cartridges, the available volume to which the airbag is inflated is limited during release of the compressed gas.

[0015] Further, systems employing compressed gas cylinders/cartridges are additionally adversely affected by the weight of such systems. This problem is acknowledged in each of the aforementioned U.S. Patent Application Publication No. 2010/0184343 and U.S. Pat. No. 6,220,909. The solution offered for these systems however, is a reduction in the amount of pressurized gas required for inflating the airbag (s), thereby enabling the use of a smaller compressed gas cylinder. The smaller cylinder, then, results in a reduction of the weight of the system.

[0016] Further, the use of compressed gas cylinders/cartridges are adversely affected by legal and safety issues related to transporting them via aircraft and other commercial vehicles. In fact, manufacturers of avalanche systems warn that tampering with such cylinders/cartridges can life-endangering.

[0017] Still further, logistical delays involved with re-filling compressed gas cylinders/cartridges present an additional inconvenience or constraint on their use.

[0018] Likewise, restrictions on shipping, mailing, transporting, importing and exporting, and certifying compressed gas cylinders/cartridges provide additional constraints and inconvenience.

[0019] Particularly in view of the one-time use of compressed gas cylinders/cartridges, their use in training and

demonstration purposes is particularly limited, inasmuch as for each deployment a new or re-filled cylinder or cartridge is required.

[0020] In addition, compressed gas containers inherently give rise to potential safety issues for the known systems. For example, manipulation at the closure or at the container can trigger an explosion, creating a risk of injury and death, even for bystanders. Further, for their systems, ABS and Snow-pulse explain that only original containers provided by them are to be used and that empty containers are to be refilled at their shops. An advisory for use of such containers explains that each supplied container has a sticker, giving its total weight and the date of filling, and that readiness for use can only be assured by weighing the container again and comparing it to the weight written on the sticker.

[0021] The aforementioned U.S. Pat. No. 6,220,909 discloses a compressed gas system whereby the gas release grip mechanism is made detachable with respect to the compressed gas unit so as to avoid an unintentional or erroneous triggering causing inflation of the airbags. In this way, the release grip is not hooked up to the compressed gas unit—which must then be accomplished prior to use, such as during skiing or hiking—while the user is on a mountain cableway, on a train, in a restaurant, on a bus, or on a trail, e.g., prior to intended use. Of course, the user must then remember to re-connect the system before he begins skiing, snowboarding, or hiking, for example, i.e., where an avalanche condition is a possibility.

SUMMARY

[0022] The present invention relates to an airbag system which overcomes all of the aforementioned negative aspects of compressed gas systems.

[0023] More particularly, the present invention is directed to an airbag system which includes an inflation device using 100% ambient air to inflate the airbag(s). Therefore, not only does the invention use less compressed gas than known rescue systems, no compressed gas is used. That is, the system of the invention utilizes no compressed gas cylinder or cartridge, i.e., no compressed gas container. Instead, inflation of the airbag(s) is achieved with an electrically powered device.

[0024] Nevertheless, a system according to the invention can achieve airbag inflation times of under 5 seconds at -20° C., and, more particularly, inflation can be achieved in as little as 2½ seconds at -20° C.

[0025] Rather than inflation being provided by the release of gas from a compressed air cartridge or cylinder, the invention utilizes inflation provided by an electric power source, such as an electric motor. The electric motor can be either a brushed or a brushless direct current electrical motor, the latter being either of the inrunner or the outrunner configuration, with digital control.

[0026] To these and other ends, the invention provides for an airbag system that includes:

- [0027] at least one inflatable airbag;
- [0028] means for inflating the airbag(s), the airbag system not including a compressed gas container;
- [0029] a supporting device for supporting on a person, or on equipment used by the person, the inflatable airbag(s) and the inflating means.

[0030] Moreover, the invention provides for an airbag system that includes:

- [0031] at least one inflatable airbag;
- [0032] means for inflating the airbag(s) with 100% ambient air to a volume of at least 100 liters in no more than 5 seconds, such as within 2½ seconds;
- [0033] a supporting device for supporting on a person, or on equipment used by the person, the inflatable airbag(s) and the inflating means.

[0034] Still further, in a particular embodiment, the invention provides for an airbag system that includes:

- [0035] at least one inflatable airbag;
- [0036] an air movement device;
- [0037] an electric power source for moving a portion of the air movement device, such as one or more fan blades, to move air to inflate the airbag(s);
- [0038] a supporting device for supporting on a person, or on equipment used by the person, the inflatable airbag(s) and the electric power source.

[0039] Further, the power source according to a particular embodiment includes an electric motor and a power supply, the system further including a controller for controlling the electric motor and power supply.

[0040] Further, in this regard, the controller includes an electronic switch for actuating the power supply for inflation of the airbag(s) by means of the air movement device.

[0041] Still further, the controller includes a trigger carried during use for manual activation by the person for manually triggering the switch or by wireless remote activation by the person, such as for activating a system associated with equipment, such as a snowmobile.

[0042] The supporting device of the system includes a structure to support the airbag(s) in a non-inflated pre-deployment position and in an inflated deployment position. In the inflated deployment position, if the system is worn by the person, in a particular embodiment of the invention, the airbag(s) include(s) at least a portion positioned proximate the person's head. In this, or another, particular embodiment, in the inflated deployment position, the airbag(s) extend(s) at least from behind and to both sides of the person's head.

[0043] In a particular embodiment, the supporting device for supporting the airbag(s) and the electrical power source can include a harness structured and arranged to carry the inflatable airbag(s) on the person's back. In this regard, the harness can take the form of shoulder straps and a waist belt.

[0044] More particularly, the supporting device can comprise a backpack structured and arranged to carry the inflatable airbag(s) on the person's back, the backpack including, e.g., shoulder straps and a waist belt.

[0045] Still further, in a particular embodiment, the air movement device includes at least one ambient air intake as well as an ambient air output leading to said at least one inflatable airbag, with a passageway downstream of the ambient air intake(s) and upstream of the ambient air output. The movable surface, such as one or more fan blades, is mounted in the passageway for drawing in ambient air from the ambient air intake(s) and for pushing the ambient air through the ambient air output to the airbag(s) for inflation of same.

[0046] The electric power source further includes a power supply, whereby power is supplied to the motor by any of a number of options, including rechargeable batteries, disposable batteries, fuel-cells, or solar energy. For example, lithium-polymer (LiPo) batteries are suitable. In a particular embodiment, a heated battery or a self-heated battery can be employed in the invention. In this regard, the battery selected for use can be merely insulated for the conditions/temperatures of use. In another embodiment, a self-heating battery

pack can be employed. In this regard, as exemplary, a self-heated battery can take the form of (1) the battery running a small secondary resistance heater controlled via a thermostat, or (2) a battery that charges and discharges to a capacitor, or similar component, and generates heat through the internal resistance and endothermic nature of the battery. The control can range from a thermostat to a solid-state circuit with a thermocouple or even monitoring the actual battery output potential and/or internal resistance.

[0047] Further, control of the motor and electrical power supply can be achieved by digital controllers of various types (voltage, heat, pressure, time, current, cycles, RPM, remote triggering via radio, etc. can all be controlled electronically). Optionally, a gyroscopic or other attitude-sensing switch can be employed to enable emergency/automatic activation of the motor (and inflation of the airbag(s)) upon sensing an extreme upset condition of the wearer, or piece of equipment supporting the system of the invention, such as a "head-over-heels" tumbling, e.g., optionally coupled with a time duration delay to avoid inadvertent activation. Such a switch, if employed, could be fitted with a manual cut-out switch to allow the wearer, or operator, to activate such automatic operation only prior to avalanche-prone areas or otherwise only in situations determined by the wearer or operator.

[0048] The ambient air is moved into the airbag and pressurized by means of any one of, or a combination of, air-movement devices including, but not restricted to the following: a ducted fan blower; a rotary or centrifugal fan/compressor; an axial fan/compressor (turbine); a rotary vane pump/blower/compressor; a gear pump; a squirrel-cage blower/fan.

[0049] The aforementioned devices can all be used in single or multi-stage configurations, as well as in series or parallel configurations, as well as in combinations of the different types of devices to create the specific volumes, fill-rates, and pressures of air as needed for specific airbag applications.

[0050] The weight of a system according to the invention, compared to the weight of known compressed gas systems, can be reduced by as much as 50% for equivalent amounts of inflation volume and pressure.

[0051] The system can deliver continuous and very high volume and pressure of gas dependent on the electrical supply which can easily be increased or decreased as required. A system according to the invention can be deployed as many as 50 times or more between battery charges.

[0052] The airbag system of the invention is not limited to a particular shape of the airbag itself. Instead, the invention can be implemented with airbags of any known shape and, for a given system, either one, two, or more airbags can be used. The total volume would be within a range of approximately 150-300 liters for an airbag system for personal use, such as being attached via a harness system, such as a backpack.

[0053] The specific intended uses of an airbag system according to the invention are for personal protection in a wearable backpack configuration, and also for equipment flotation (such as for snowmobiles, etc.). In the latter case, the system can be made to be remotely activated. The airbag system of the invention can be incorporated into various forms of support for the various components of the system to be applied to or worn by a person or an item to be rescued. For example, such support can take the form of a frame or harness, such as that utilized as part of a backpack, or as part of a climbing harness, or as part of an article of clothing, such as a jacket, a vest, a coat, or other item of apparel. In this regard,

the expression "supporting device" can be used to reference any such apparatus that allows components of the airbag system of the invention to be worn by or applied to a person or item to be rescued. For recovery of a piece of equipment, rather than as a personal device, the airbag volume can be adjusted accordingly. For a snowmobile, which might be generally four times the weight of a person, the airbag volume could be within the range of 500-1000 liters.

[0054] In general, the invention encompasses an airbag device, such as those described in aforementioned patent documents, but in which the compressed air source and associated components required for inflation via compressed air, according to such known systems, which are replaced with an electrically powered air supply device and necessary components, described herein, with the aforementioned advantages resulting from not utilizing such compressed air source and various components required for implementation of compressed air systems. To this end, therefore, the disclosures of the aforementioned patents and patent applications are hereby incorporated by reference thereto in their entireties. In addition, although the airbag device is applicable to survival and rescue from an avalanche, i.e., rescue situations while on snow, the airbag system of the invention also has applicability to rescue situations on water, such as after a boat or other watercraft capsizes or otherwise loses its buoyancy.

BRIEF DESCRIPTION OF DRAWINGS

[0055] Other characteristics and advantages of the invention will become apparent from the description which follows, with reference to the annexed drawings which are provided only by way of non-limiting examples, and in which: [0056] FIG. 1 is a schematic front view of backpack with which an airbag system according to the invention is incorporated, showing an airbag of the system in an inflated, deployed configuration;

[0057] FIG. 2 is a side view of the backpack and airbag system of FIG. 1;

[0058] FIG. 3 is a view similar to that of FIG. 1, illustrating components of the airbag system of the invention which are incorporated into the backpack;

[0059] FIG. 4 is a view like that of FIG. 3, illustrating an alternative embodiment;

[0060] FIG. 5 is a schematic view of an assembly of components mounted to an airbag, representing a specific non-limiting embodiment of the invention;

[0061] FIG. 6 an exploded perspective view of the components of FIG. 5; and

[0062] FIG. 7 is an exploded side view of the components of FIG. 6.

DETAILED DESCRIPTION

[0063] The following detailed description is that of particular embodiments, including exemplary structures, materials, and arrangements of parts, as well as exemplary methods. However, it is to be understood that this description is presented for the purpose of enhancing an understanding of the invention and not to limit it to such particular embodiments and methods.

[0064] FIGS. 1 and 2 illustrate an airbag system 1 according to the invention, incorporated with a backpack 2, with an airbag 3 in a deployed, i.e., inflated, configuration.

[0065] The backpack provides a structure for supporting various components of the airbag system, as further described

below in connection with FIGS. 3 and 4. The backpack includes an upright panel 4, adapted to lie against the back of the wearer, to provide rigidity to the backpack and support for components of the airbag system, as well as a pair of shoulder straps 5 and a waist belt 6, both with adjustable coupling elements, and a pad 7 for support against the lower back of the wearer. A backpack such as that disclosed in commonly assigned U.S. Patent Application Publication No. 2008/0041906, the disclosure of which is hereby incorporated by reference thereto in its entirety, having an upright panel (referred to therein as a sheet frame 42, e.g.), could be utilized in the invention to support certain components thereof.

[0066] The backpack 2 can include a main compartment and various pockets like those of conventional backpacks. Alternatively, rather than comprising such attributes of conventional backpacks, only those components necessary for supporting the various components of the airbag system can be utilized. Thus, rather than having the airbag system incorporated into a backpack, it is to be understood that the invention can be incorporated with what can be characterized as merely a supporting device, such as a harness. In this regard, therefore, the supporting device can be devoid of a main compartment and various pockets, e.g., although it can include a compartment, such as compartment 8, for storing the airbag 3 prior to inflation.

[0067] In alternative embodiments, not shown, the airbag system of the invention can be incorporated with any of various articles of clothing, such as jackets or vests, for example. That is, such articles of clothing can have incorporated therein various supporting devices for the components of the airbag system.

[0068] Although not shown with further particularity, the uninflated airbag(s) can be stored in compartment 8, prior to activation, and released from the compartment upon inflation of the airbag(s), in the manner of the systems disclosed in the aforementioned patents and publications, such as U.S. Pat. No. 6,158,380 and U.S. Patent Application Publication No. 2010/0184343, for example, the disclosures of such patents and publications being incorporated by reference thereto for this purpose.

[0069] To facilitate inflation of the airbag with 100% ambient air, at least one of the sides of the backpack includes a screen or ventilated panel 9 to enable the ambient air to be drawn in.

[0070] FIGS. 3 and 4 schematically illustrate components of a particular embodiment of an airbag system according to the invention. Details of the airbag itself, deployed as in FIGS. 1 and 2, as well as the backpack, are depicted in broken lines.

[0071] FIG. 3 illustrates a conduit 10, providing an ambient air passageway for conducting air from the intake, such as through the ventilated panel 9, to an output, the latter leading to the airbag 3 for inflation. Alternatively, rather than a single conduit, a pair of such conduits, such as conduits 10a, 10b in FIG. 4, can be employed, each pulling in ambient air from a respective ventilated panel 9 on one of the sides of the backpack. The conduit(s) can be mounted on, or can be supported by, the panel 4 of the backpack.

[0072] Proximate the output end of the conduit 10 in FIG. 3, or at the junction of the conduits 10a, 10b, proximate the output end thereof, in FIG. 4, an air movement device, such as a fan, having a plurality of blades, is positioned within the conduit for drawing in ambient air from the intake and pushing the air through the output for inflating the airbag 3.

[0073] The invention encompasses other forms of air movement devices for achieving the objectives of the invention, particularly that of fully inflating an airbag volume (such as at least 150 liters or more) within a predetermined time period (such as no greater than five seconds, or less). For example, a ducted fan blower, a rotary or centrifugal fan/compressor, an axial fan/compressor (turbine), a rotary vane pump/blower/compressor, a gear pump, and a squirrel-cage blower/fan are all possibilities within the scope of the invention.

[0074] Further, in this regard, the fan/blower/compressor (i.e., generally referred to here as an "air movement device" or a part of such device) can be a single or a multi-stage configuration. To achieve higher pressures or a stronger draw of ambient air (if required based upon the application), multi-stage blowers in series, e.g., can be used (as with axial turbine compressors or two centrifugal vacuum cleaners). To achieve higher flow/fill rates or redundancy for safety, parallel systems can be used. A combination of two types of blowers also can be used (such as a rotary vane pump for high pressure for initial airbag deployment used with an axial ducted fan for very high volume air movement).

[0075] With further reference to the illustrated embodiment, the air movement device (hereafter "fan," for convenience) is powered by an electric motor, such as an inrunner or outrunner brushless DC motor, also positioned within the conduit proximate the output end thereof, with the fan being mounted on the output shaft of the motor. Alternatively, the motor can be mounted exteriorly of the conduit, supported on the panel 4 of the backpack, with a right-angle drive that couples the shaft of the fan with the output shaft of the motor or, in the case of an inrunner brushless motor, with the fan mounted on the output shaft of the gearbox which is mounted to the motor. The invention encompasses other types of electric motors, as well, which are suitable for achieving the objectives of the invention. More particularly, FIGS. 3 and 4 schematically illustrate an outrunner brushless DC motor 11, with a fan 12 mounted on its output shaft.

[0076] Also supported proximate the motor and fan, and wired to the motor, is the electric power source, in the form of a battery 13, such as of the lithium-polymer (LiPo) type, and a controller 14, such as that which provides digital control. The invention encompasses other forms of power supply and control for achieving the objectives of the invention, including, e.g., a heated or self-heated battery.

[0077] Although the airbag illustrated in the drawings, such as in FIGS. 1 and 2, extends from the rear and along both sides of the head of the wearer, the invention is not limited to such particular shape and can be suitably practiced with other shapes. In addition, although a single airbag is shown, the invention can be suitably practiced with a pair of airbags, as disclosed, e.g., in U.S. Pat. No. 6,158,380 and other documents, or more than two airbags.

[0078] Further, the total volume of the airbag 3 could be approximately 150 liters, although the volume can be larger if desired, such as within a range of approximately 150-300 liters, inasmuch as there would not appear to be a large penalty, such as an additional increment of weight of the system, for utilizing airbag(s) with a larger volume.

[0079] On at least one of the shoulder straps, a trigger 15, or activation switch, is positioned, such trigger being coupled to the controller 14 via wire 16 (see FIGS. 3, 4). The trigger can be any of several types, requiring a push, a pull, a twist, or other manipulation for initiating the electrical activation of

the system and the inflation of the airbag(s). In certain embodiments encompassed by the invention, the trigger has a size and shape that particularly facilitates manipulation with a gloved hand. The wired electrical connection 16, extending between the trigger 15 and the controller 14, either along or within the structure of the strap to which the trigger is mounted.

[0080] In operation, when the wearer (skier, hiker, snowmobiler, e.g.) becomes aware of an avalanche situation, he/she manipulates the trigger 12, resulting in a signal being sent to the controller 14, thereby powering the motor 11 to begin rotation of the fan 12, for drawing ambient air through the passageway(s) 10 or 10a, 10b, to the output, for inflation of the airbag 3.

[0081] According to a particular embodiment of the invention, the fan pumps ambient air into the airbag for a predetermined time. For fully inflating a 150-liter airbag, the “on” signal from the controller to the motor could be transmitted for at least five seconds. Alternatively, for safety reasons, the fan could be powered for a longer duration, i.e., greater than a calculated full-inflate time, greater than five seconds, i.e., such as 10-15 seconds or more, for the aforementioned 150 liter airbag. This could accommodate variations in ambient conditions, such as including variations in temperature and pressure, which could affect a predetermined full-inflate time.

[0082] In a simplified embodiment according to the invention, the airbag system includes, in addition to the airbag(s), an air movement device (such as a fan), an electric motor, a power source (such as a battery), and an on/off switch, whereby, when the wearer becomes aware of an avalanche, the switch is manipulated, thereby powering the motor, which turns the fan until the power source is depleted or until the wearer were to move the switch to the off position.

[0083] In an enhanced embodiment, e.g., the airbag system of the invention can include an air pressure sensor to monitor pressure within the airbag, whereby the motor would be signalled to cycle off power to the fan upon attaining a predetermined pressure. In fact, each of the aforementioned time cycles for inflation (i.e., five seconds, or 10-15 seconds, e.g.) and the pressure-sensed power-control for inflation could be used separately in respective embodiments, or in combination. In the latter case, e.g., the pressure sensing could be used as a cut-off for a time-dependent system, whereby power would be interrupted before the end of the time duration if pressure reaches a set level.

[0084] In any case, the invention encompasses the alternate cycling of power to the fan, i.e., on and off, after an avalanche but prior to recovery, either as a function of a set time interval or as a function of an airbag pressure drop below a set level. This feature, of course, is unavailable with known systems that rely upon a one-time-use compressed gas container to inflate the airbag(s). Further, in this regard, modern battery technology, including LiPo batteries, e.g., enables multiple airbag deployments between charges.

[0085] In yet an additional enhanced embodiment of the invention, the airbag is fitted with an overflow valve (or pressure-relief valve), so that the fan (or blower or compressor) delivers breathable air to the vicinity of the user’s head. In this regard, such a valve supplies breathable air continuously or in incremented cycles, whereby the fan is cycled on and off, as long as the power supply is not depleted. The overflow air could be delivered manually by the wearer by means of an appropriate control member positioned near the trigger, e.g.,

and/or automatically (for safety reasons, inasmuch as the wearer might be in an incapacitated state), such as by means of an appropriate control algorithm.

[0086] For the aforementioned enhanced embodiment, the supply of breathable air, post-avalanche, would be drawn in via the intake vents/screen(s) 9, particularly if either side of the backpack, and vents/screen(s) 9, are exposed, or from the snow-pack.

[0087] FIGS. 5, 6, and 7 are directed to a specific, yet non-limiting, embodiment of the invention. FIG. 5 illustrates a motor, to which a blower rotor is attached, for drawing in ambient air to an airbag through a dual source ducting arrangement (similar to that of FIG. 3). A flange mounts the motor and certain associated components to the airbag, a cut-away portion of the airbag being shown for convenience in FIG. 5. Adhesive or mechanical fastener(s) can be used, if necessary, to secure the flange to the airbag if determined to be advantageous or necessary. The flange is shown with a wiring port through which the electrical connection extends between the digital speed controller and the motor.

[0088] FIGS. 5 and 7 identify and describe the details of specific components of an exemplary embodiment for carrying out the invention. These details are presented only for the purpose of enhancing an understanding of the invention, although the scope of the invention is not limited to such details, nor are the details shown and described in FIGS. 5-7 intended to represent essential elements nor essential limitations of the invention.

[0089] In this regard, for example, the invention illustratively disclosed herein—with regard to FIGS. 5-7 as well as with regard to the invention shown in the other drawing figures and described elsewhere herein—suitably may be practiced in the absence of any element which is not specifically disclosed herein.

[0090] Finally, although the invention has been described with reference to particular means, structures, materials, and embodiments, it is to be understood that the invention is not limited to the particulars explicitly disclosed and extends to all equivalents within the scope of the claims.

[0091] In addition to the foregoing, the invention disclosed herein with reference to exemplary embodiments suitably may be practiced in the absence of any element which is not specifically disclosed herein.

1. An airbag system comprising:
 - at least one inflatable airbag;
 - means for inflating said at least one airbag, said airbag system not including a compressed gas container;
 - a supporting device for supporting on a person said at least one inflatable airbag and said means.
2. An airbag system comprising:
 - at least one inflatable airbag;
 - means for inflating said at least one airbag with 100% ambient air to a volume of at least 100 liters in no more than 5 seconds;
 - a supporting device for supporting on a person, or on equipment used by the person, said at least one inflatable airbag and said means.
3. An airbag system comprising:
 - at least one inflatable airbag;
 - an air movement device;
 - a power source for moving a portion of said air movement device to move air to inflate said at least one airbag;

a supporting device for supporting said at least one inflatable airbag and said power source on a person or on equipment used by the person.

4. An airbag system according to claim 3, wherein: the airbag system does not include a compressed gas container.

5. An airbag system according to claim 3, wherein: said power source comprises an electrical motor.

6. An airbag system according to claim 5, wherein: said electrical motor comprises a brushless electrical motor.

7. An airbag system according to claim 6, wherein: said brushless electrical motor has one of an inrunner and an outrunner configuration.

8. An airbag system according to claim 3, wherein: said power source further comprises:
an electrical motor;
a power supply;

the airbag system further comprises a controller for controlling said electrical motor and said power supply.

9. An airbag system according to claim 8, wherein: said controller includes an electronic switch for actuating the power supply for inflation of the at least one airbag by means of the air movement device.

10. An airbag system according to claim 9, wherein: said controller includes a trigger carried during use for manual activation by the person for triggering the switch.

11. An airbag system according to claim 9, wherein: said controller includes a trigger carried during use for wireless remote activation by the person.

12. An airbag system according to claim 3, wherein: said supporting device comprising a structure to support said at least one airbag in a non-inflated pre-deployment position and in an inflated deployment position; in said inflated deployment position, said at least one airbag comprises at least a portion positioned proximate the person's head.

13. An airbag system according to claim 12, wherein: in said inflated deployment position, said at least one airbag extends at least from behind and to both sides of the person's head.

14. An airbag system according to claim 3, wherein: said supporting device for supporting said at least one inflatable airbag and said electrical power source on a person comprises a harness structured and arranged to carry said at least one inflatable airbag on the person's back.

15. An airbag system according to claim 14, wherein: said harness comprises shoulder straps and a waist belt.

16. An airbag system according to claim 3, wherein: said supporting device for supporting said at least one inflatable airbag and said electrical power source on a person comprises a backpack structured and arranged to carry said at least one inflatable airbag on the person's back.

17. An airbag system according to claim 16, wherein: said backpack comprises shoulder straps and a waist belt.

18. An airbag system according to claim 3, wherein: said portion of said air movement device comprises a movable surface moved by said electric power source.

19. An airbag system according to claim 3, wherein: said movable surface comprises a fan blade.

20. An airbag system according to claim 18, wherein: said air movement device further comprises:
at least one ambient air intake;
an ambient air output leading to said at least one inflatable airbag;
a passageway downstream of said at least one ambient air intake and upstream of said ambient air output;
said movable surface is mounted in said passageway for drawing in ambient air from said at least one ambient air intake and for pushing said ambient air through said ambient air output to said at least one airbag to inflate said at least one airbag.

21. An airbag system according to claim 20, wherein: the airbag system is structured and arranged to inflate said at least one airbag to an inflated deployment condition with 100% ambient air from said passageway.

22. An airbag system according to claim 20, wherein: said movable surface comprises a fan blade.

* * * * *